

Plasma

Performance Data Sheet PDS-30003

EQP Endcaps

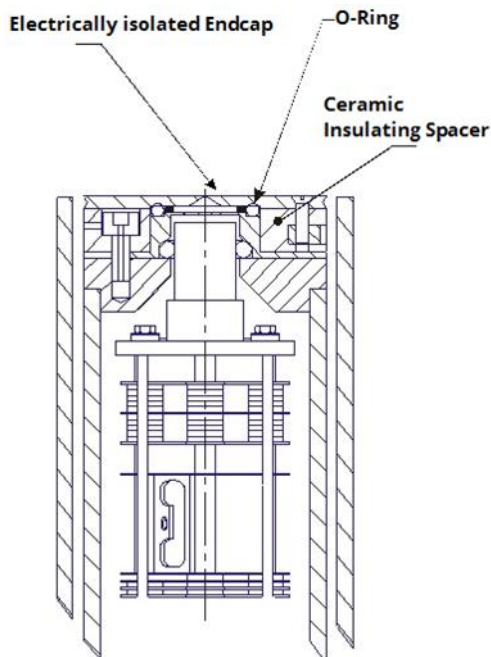

Figure 1

The standard EQP endcap electrode is a metal plate which is an integral part of the instrument's grounded cover tube. Ion and other species are sampled through a small (100µm) central orifice in the electrode. Alternative endcap electrodes can be supplied. One alternative is an electrically-isolated electrode (EIE) such as that shown in Figure 1.

The metal electrode has a central sampling orifice and is mounted on an insulating Macor disc whose surfaces are not exposed to incident charged particles passing through the metal orifice. The EIE is suitable for experiments designed to simulate the

arrival of energetic ions at a metal surface which is immersed in a plasma and reaches a "floating potential", V_f , as the result of its exposure to fluxes of ions, electrons and other plasma species. If the EIE becomes negatively-charged, (negative V_f), the ion energy distributions (IEDs) of positive ions sampled through the sampling orifice are identical with those measured for a grounded orifice (as the ions are both accelerated and decelerated by the same amount). Figure 2 shows typical data for Ar^+ ions in an argon plasma when sampled through an EIE at V_f values of -5, -10, and -15 volts. The IEDs of ions impacting on the surface of the EIE are obtained by adding the appropriate value of V_f to the energies shown in the figure.

It is more common for the EIE to become positively charged (V_f positive). Figure 3 shows the IEDs measured for Ar^+ ions in an argon plasma at a pressure of 7mTorr for RF input powers of 2 and 6 Watts. The IEDs measured when the EIE was grounded are also shown. Independent measurements showed V_f for both 2 and 6 Watts to be around 6 volts. The IEDs show that ions with energies less than 6eV are not transmitted by the EIE. It is important to remember that the IEDs as plotted are the energies of the ions with respect to ground. The energies of the ions impacting on the floating electrode are obtained by subtracting V_f eV from the values shown, i.e. the energies range from 0 to 14eV.

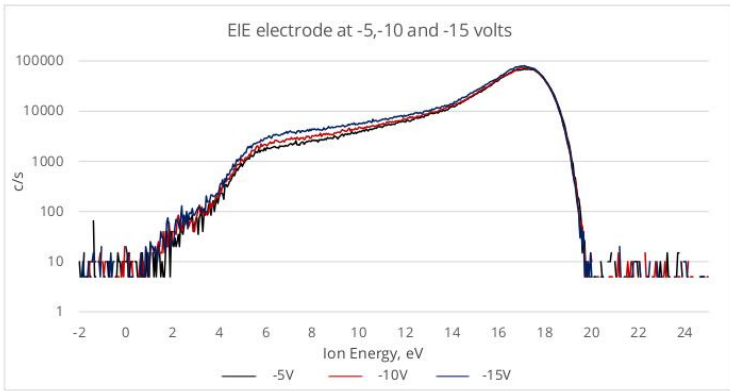

Figure 2

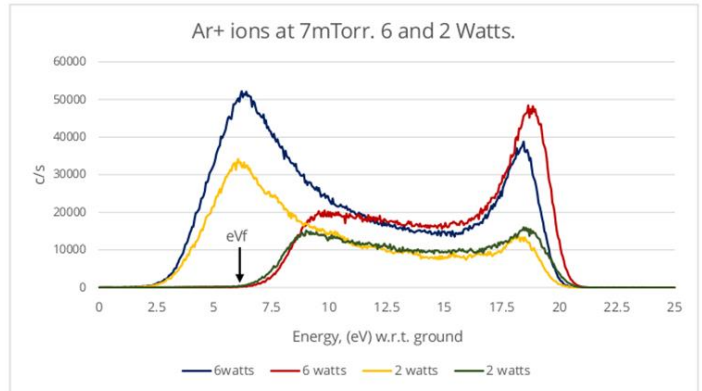

Figure 3

Figures 4a and 4b show a comparison between the IEDs of Ar^+ and Ar^{++} ions in a plasma of 10 Watts RF at a pressure of 7mTorr, when sampled through an EIE either grounded or floating at a V_f of about 7 volts. The figures show far fewer low energy doubly-charged ions sampled through the grounded EIE (as expected since they are less subject to charge-exchange collisions). The rejection of ions with energies less than $q \cdot V_f$ (where q for Ar^{++} is twice that for Ar^+) by the floating EIE is clear

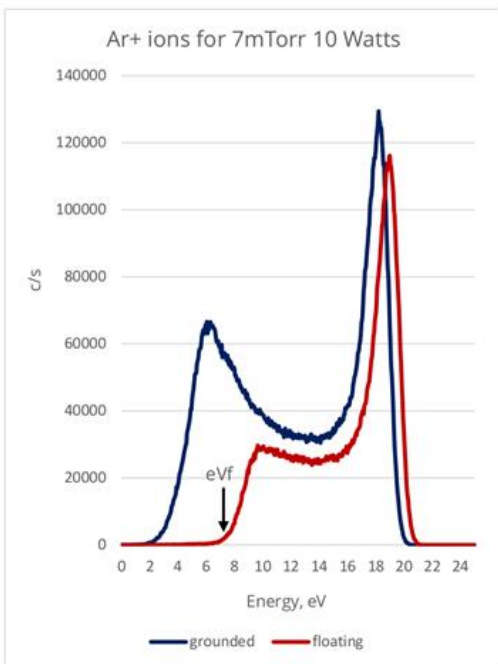

Figure 4a

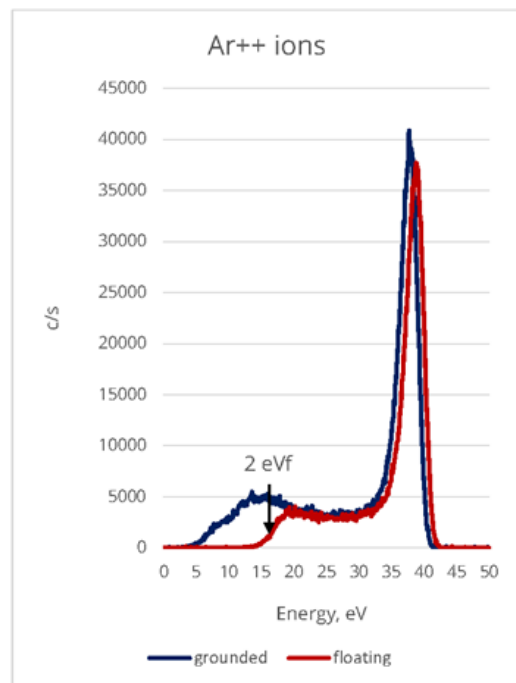

Figure 4b